



SYSTÈMES DE GESTION DU CARBURANT



DISTRIBUTEURS



KITS



POMPES



COMPTEURS



PISTOLETS

EX100 DRUM

CARACTÉRISTIQUES

- FONCTIONNEMENT CONTINU
- PROTECTION THERMIQUE
- UNITÉ D'ASPIRATION AVEC FILTRE INTÉGRÉ
- VANNE DE DÉRIVATION
- VERSION UL DISPONIBLE

PIUSI EX100 DRUM est le nouveau kit de transfert pour les fluides inflammables ; caractérisé par un haut débit, il travaille en cycle continu. facile à utiliser, compact, versatile, il s'adapte à toutes les conditions de travail: vous pouvez l'utiliser là où vous en avez le plus besoins.

PIUSI EX100 DRUM est certifié ATEX et il répond aux directives traitant de l'utilisation de matériel dans les atmosphères potentiellement explosives. PIUSI EX140 DRUM est certifié ATEX et il répond aux directives traitant de l'utilisation de matériel dans les atmosphères potentiellement explosives.



PERFORMANCES

JUSQU'À
100 L/MIN

DÉBIT

AC
PUISSANCE

TENSION



EX100 DRUM /A140/K150/5MT



EX100 DRUM /A140/5MT

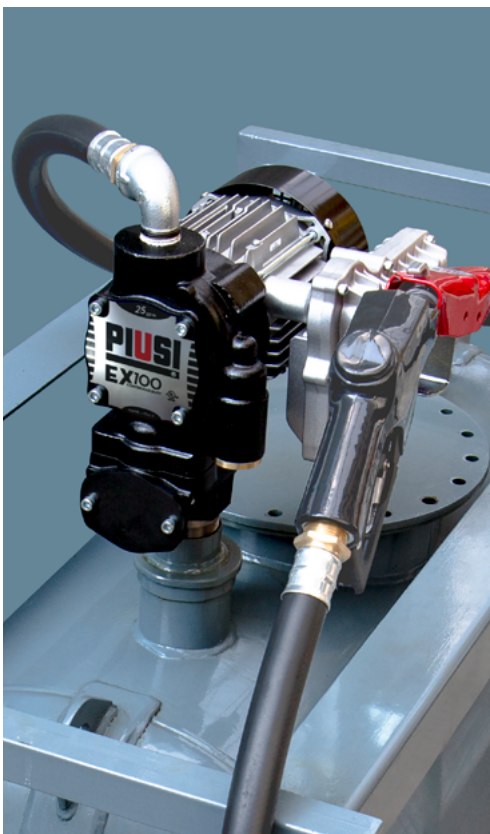

NOS POMPES SONT CONFORMES AUX MARQUAGES ATEX/IECEx SUIVANTS

II	2	G	Ex	d	IIA	T4	Gb
GRUPE	CATÉGORIE	TYPE D'ATMOSPHÈRE EXPLOSIBLE	PRÉFIXE PERMANENT	MODE DE PROTECTION	GRUPE DE GAZ	CLASSE DE TEMPÉRATURE	INDICE DE PROTECTION

PACKAGING

CODE	POIDS		PACKAGING		
	KG	LBS	MM	INCH	PCS/BOÎTE
FO0391010	25	55	240X400X350	10X16X15	1
FO0391020	25	55	240X400X350	10X16X15	1
FO0391300	30	66	400X600X430	16X24X17	1
FO0391320	30	66	400X600X430	16X24X17	1
FO0391340	30	66	400X600X430	16X24X17	1
FO0391310	32	70	400X600X430	16X24X17	1
FO0391330	32	70	400X600X430	16X24X17	1
FO0391350	32	70	400X600X430	16X24X17	1



FILTRAGE



SURVEILLANCE DES LIQUIDES



ENROULEUR



ACCESSOIRES



MERCHANDISE



AIR



ANTIGEL



AdBlue®



BIODIESEL



DIESEL



ALIMENTATION



ESSENCE



GRAISSE



KÉROSÈNE



HUILE



EAU



LAVE-GLACE

GRAPHIQUE

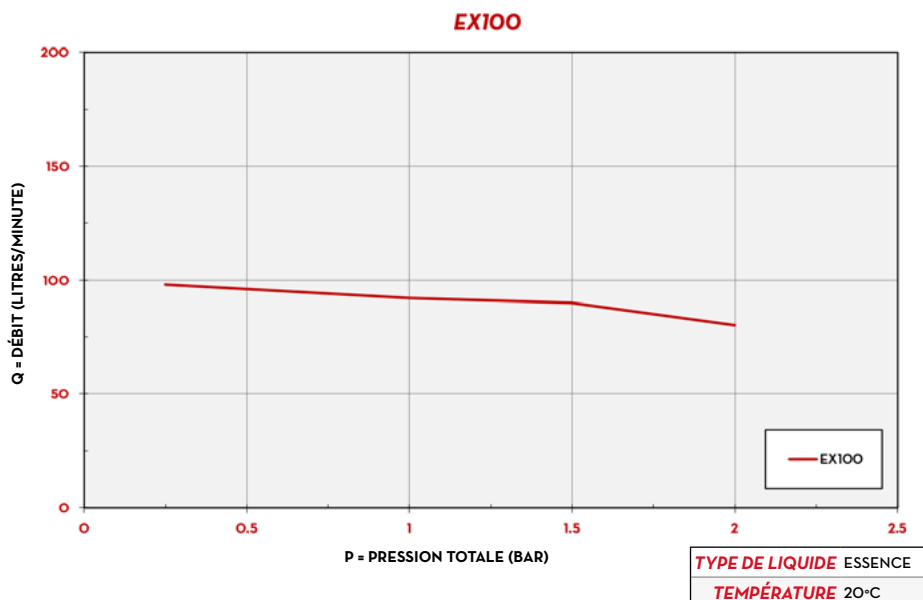

DIMENSIONS

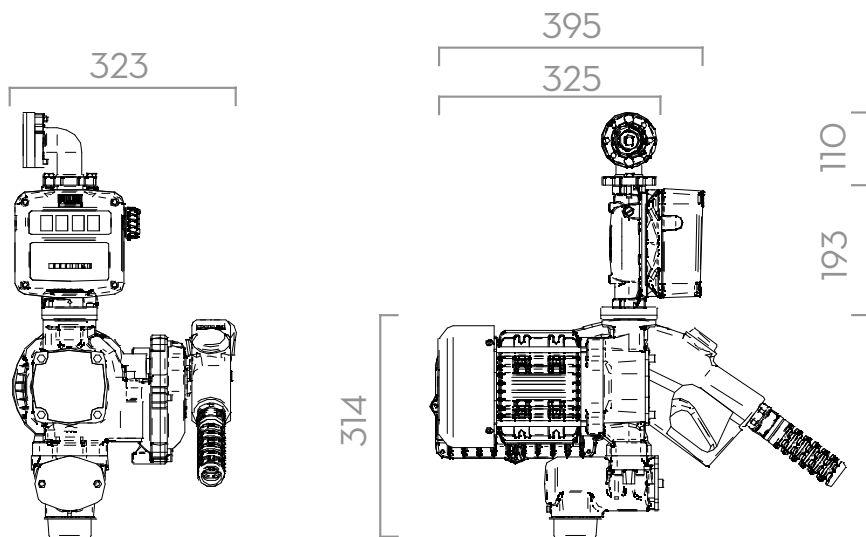

Dimensions exprimées en millimètres

CONTENU DE L'EMBALLAGE

- POMPE EX100
- SUPPORT DE PISTOLET
- RACCORD 2"
- COUDE BRIDÉ 90°
- COMPTEUR K150 ATEX (SUR CERTAINES VERSIONS)
- PISTOLET AUTOMATIQUE A140 ATEX (SUR CERTAINES VERSIONS)
- TUYAU DE DISTRIBUTION (SUR CERTAINES VERSIONS)
- MANUEL D'INSTRUCTIONS

DÉTAILS



COMPOSANTS

- POMPE: EX100 PAG. 96
- COMPTEUR: K150 ATEX PAG. 130
- PISTOLETS: A140 ATEX PAG. 156

DONNÉES TECHNIQUES

CODE	DESCRIPTION	TYPE DE LIQUIDES	DÉBIT		TENSION			CYCLE DE SERVICE	ENTRÉE	SORTIE	COMPTEUR	TUYAU DE DISTRIBUTION	PROTECTION CONTRE LE PLIAGE	ULTRA HI-FLOW AUTO NOZZLE
			L/MIN	GPM	AC V./HZ	PUISSANCE/WATT	AMP. MAX.							
FO0391010	(EX) EX100 DRUM 230V/50HZ (PUMP ONLY)	D G K	100	25	230/50	1035	4,5	OUI	2" BSP	1" BSP	-	-	-	-
FO0391020	(EX) EX100 DRUM 230V/60HZ (PUMP ONLY)	D G K	100	25	230/60	874	3,8	OUI	2" BSP	1" BSP	-	-	-	-
FO0391300	(EX) EX100 DRUM 230/50 /A140/5MT	D G K	100	25	230/50	1035	4,5	OUI	2" BSP	1" BSP	-	D.25 5MT	OUI	A140
FO0391320	(EX) EX100 DRUM 230/60 /A140/5MT	D G K	100	25	230/60	874	3,8	OUI	2" BSP	1" BSP	-	D.25 5MT	OUI	A140
FO0391340	(EX) EX100 DRUM 250/50 /A140/5MT	D G K	100	25	250/50	1125	4,5	OUI	2" BSP	1" BSP	-	D.25 5MT	OUI	A140
FO0391310	(EX) EX100 DRUM 230/50 /A140/K150/5MT	D G K	100	25	230/50	1035	4,5	OUI	2" BSP	1" BSP	K150	D.25 5MT	OUI	A140
FO0391330	(EX) EX100 DRUM 230/60 /A140/K150/5MT	D G K	100	25	230/60	874	3,8	OUI	2" BSP	1" BSP	K150	D.25 5MT	OUI	A140
FO0391350	(EX) EX100 DRUM 250/50 /A140/K150/5MT	D G K	100	25	250/50	1125	4,5	OUI	2" BSP	1" BSP	K150	D.25 5MT	OUI	A140

(*) SUR DEMANDE, PRODUIT DISPONIBLE AVEC PLUSIEURS TENSIONS ET FRÉQUENCE DE 60 HZ. LIQUIDES COMPATIBLES : DIESEL, KÉROSÈNE, ESSENCE, MÉLANGE ESSENCE-ALCOOL MAX 15 %, AVGAS 100/100LL, JET A/A1 - ASPEN 2/4

EX100 DRUM